

INSTRUCTION MANUAL

DEWALT®

DWS780-XE

305 mm (12") DOUBLE BEVEL SLIDING COMPOUND MITER SAW

Definitions: Safety Guidelines

The definitions below describe the level of severity for each signal word. Please read the manual and pay attention to these symbols.

⚠ DANGER: Indicates an imminently hazardous situation which, if not avoided, will result in death or serious injury.

⚠ WARNING: Indicates a potentially hazardous situation which, if not avoided, could result in death or serious injury.

⚠ CAUTION: Indicates a potentially hazardous situation which, if not avoided, may result in minor or moderate injury.

NOTICE: indicates a practice **not related to personal injury** which, if not avoided, **may** result in **property damage**.

IF YOU HAVE ANY QUESTIONS OR COMMENTS ABOUT THIS OR ANY DEWALT TOOL, CALL US AT: **1800 444 224** (Aust) or **0800 339 258** (NZ).

Important Safety Instructions



WARNING: Read all instructions before operating product. Failure to follow all instructions listed below may result in electric shock, fire and/or serious injury.

READ ALL INSTRUCTIONS

Double Insulation

Double insulated tools are constructed throughout with two separate layers of electrical insulation or one double thickness of insulation between you and the tool's electrical system. Tools built with this insulation system are not intended to be grounded.

NOTE: Double insulation does not take the place of normal safety precautions when operating this tool. The insulation system is for added protection against injury resulting from a possible electrical insulation failure within the tool.

⚠ CAUTION: WHEN SERVICING USE ONLY IDENTICAL REPLACEMENT PARTS. Repair or replace damaged cords.

Safety Instructions For All Tools

This miter saw accepts the DEWALT worklight and laser attachments.

⚠ WARNING: To reduce the risk of eye injury, **ALWAYS** use eye protection when operating the miter saw.

- **KEEP GUARD IN PLACE** and in working order.
- **REMOVE ADJUSTING KEYS AND WRENCHES.** Form habit of checking to see that keys and adjusting wrenches are removed from spindle before turning tool on. Tools, scrap pieces, and other debris can be thrown at high speed, causing injury.
- **KEEP WORK AREA CLEAN.** Cluttered areas and benches invite accidents.
- **DO NOT USE THE MACHINE IN A DANGEROUS ENVIRONMENT.** The use of power tools in damp or wet locations or in rain can cause shock or electrocution. Keep your work area well-lit to avoid tripping or placing arms, hands, and fingers in danger.
- **KEEP CHILDREN AWAY.** All visitors should be kept at a safe distance from work area. Your shop is a potentially dangerous environment.
- **MAKE WORKSHOP CHILDPROOF** with padlocks, master switches, or by removing starter keys. The unauthorized start-up of a machine by a child or visitor may result in injury.
- **DON'T FORCE TOOL.** It will do the job better and be safer at the rate for which it was designed.
- **USE RIGHT TOOL.** Don't force tool or attachment to do a job for which it was not designed. Using the incorrect tool or attachment may result in personal injury.
- **WEAR PROPER APPAREL.** No loose clothing, gloves, neckties, rings, bracelets, or other jewelry to get caught in moving parts. Non-slip footwear is recommended. Wear protective hair covering to contain long hair. Air vents may cover moving parts and should also be avoided.
- **ALWAYS USE SAFETY GLASSES.** Everyday eyeglasses are NOT safety glasses. Also use face or dust mask if cutting operation is dusty. **ALWAYS WEAR CERTIFIED SAFETY EQUIPMENT:**
 - ANSI Z87.1 eye protection (CAN/CSA Z94.3)
 - ANSI S12.6 (S3.19) hearing protection
 - NIOSH/OSHA/MSHA respiratory protection

- **SECURE THE WORKPIECE.** Use clamps or a vise to hold the workpiece on the table and against the fence or when your hand will be dangerously close to the blade (within 6"). It is safer than using your hand and it frees both hands to operate tool.
- **DON'T OVERREACH.** Keep proper footing and balance at all times. Loss of balance may cause personal injury.
- **MAINTAIN TOOLS WITH CARE.** Keep tools sharp and clean for best and safest performance. Follow instructions for lubricating and changing accessories. Poorly maintained tools and machines can further damage the tool or machine and/or cause injury.
- **TURN THE MACHINE "OFF", AND DISCONNECT THE MACHINE FROM THE POWER SOURCE** before installing or removing accessories, before adjusting or changing set-ups, when making repairs or changing locations. An accidental start-up can cause injury. Do not touch the plug's metal prongs when unplugging or plugging in the cord.
- **REDUCE THE RISK OF UNINTENTIONAL STARTING.** Make sure that the switch is in the "OFF" position before plugging in the power cord.
- **USE PROPER EXTENSION CORD.** Make sure your extension cord is in good condition. If your product is equipped with a cordset, use only 3-wire extension cords that have 3-prong grounding-type plugs and 3-pole receptacles that accept the tool's plug. When using an extension cord, be sure to use one heavy enough to carry the current your product will draw. An undersized cord will cause a drop in line voltage resulting in loss of power and overheating. The following table shows the correct size to use depending on cord length and nameplate ampere rating. If in doubt, use the next heavier gage. The smaller the gage number, the heavier the cord.

MINIMUM GAUGE FOR CORD SETS

For Cable length (m):	7.5	15	25	30	45	60
Use Cable with minimum rating (Amperes)						
Tool Amperes						
0 - 3.4	7.5	7.5	7.5	7.5	7.5	7.5
3.5 - 5.0	7.5	7.5	7.5	7.5	10	15
5.1 - 7.0	10	10	10	10	15	15
7.1 - 12.0	15	15	15	15	20	20
12.1 - 20.0	20	20	20	20	25	—

- **CHECK for DAMAGED PARTS.** Before further use of the tool, a guard or other part that is damaged should be carefully checked to determine that it will operate properly and perform its intended function—check for alignment of moving parts, binding of moving parts, breakage of parts, mounting and any other conditions that may affect its operation. A guard or other part that is damaged should be properly repaired or replaced. Do not use tool if switch does not turn it on and off.
- **USE RECOMMENDED ACCESSORIES.** Use only accessories that are recommended by the manufacturer for your model. Accessories that may be suitable for one tool may be hazardous when used on another tool. Consult the instruction manual for recommended accessories. The use of improper accessories may cause risk of injury to persons.
- **NEVER STAND ON TOOL.** Serious injury could occur if the tool is tipped or if the cutting tool is unintentionally contacted.
- **NEVER LEAVE TOOL RUNNING UNATTENDED. TURN POWER OFF.** Don't leave tool until it comes to a complete stop. Serious injury can result.
- **DO NOT OPERATE ELECTRIC TOOLS NEAR FLAMMABLE LIQUIDS OR IN GASEOUS OR EXPLOSIVE ATMOSPHERES.** Motors in these tools may spark and ignite fumes.
- **STAY ALERT, WATCH WHAT YOU ARE DOING, AND USE COMMON SENSE. DO NOT USE THE MACHINE WHEN YOU ARE TIRED OR UNDER THE INFLUENCE OF DRUGS or ALCOHOL.** A moment of inattention while operating power tools may result in injury.

Additional Safety Rules For Miter Saws

⚠ WARNING: Do not allow familiarity (gained from frequent use of your saw) to replace safety rules. Always remember that a careless fraction of a second is sufficient to inflict severe injury.

- **DO NOT OPERATE THIS MACHINE** until it is completely assembled and installed according to the instructions. A machine incorrectly assembled can cause serious injury.
- **OBTAIN ADVICE** from your supervisor, instructor, or another qualified person if you are not thoroughly familiar with the operation of this machine. Knowledge is safety.

- **STABILITY.** Make sure the miter saw is placed on a secure supporting surface and does not slip or move during use. If the mobility kit is installed, raise the moveable caster(s) so saw is in its stationary position.
- **FOLLOW ALL WIRING CODES** and recommended electrical connections to prevent shock or electrocution. Protect electric supply line with at least a 15 ampere time-delay fuse or a circuit breaker.”
- **MAKE CERTAIN** the blade rotates in the correct direction. The teeth on the blade should point in the direction of rotation as marked on the saw.
- **TIGHTEN ALL CLAMP HANDLES,** knobs and levers prior to operation. Loose clamps can cause parts or the workpiece to be thrown at high speeds.
- **BE SURE** all blade and blade clamps are clean, recessed sides of blade clamps are against blade and arbor screw is tightened securely. Loose or improper blade clamping may result in damage to the saw and possible personal injury.
- **ALWAYS USE A SHARP BLADE.** Check the blade to see if it runs true and is free from vibration. A dull or a vibrating blade can cause damage to the machine and/or serious injury.
- **DO NOT OPERATE ON ANYTHING OTHER THAN THE DESIGNATED VOLTAGE** for the saw. Overheating, damage to the tool and personal injury may occur.
- **DO NOT WEDGE ANYTHING AGAINST THE FAN** to hold the motor shaft. Damage to tool and possible personal injury may occur.
- **DO NOT** force cutting action. Stalling or partial stalling of motor can cause damage. To the machine or blade and/or serious injury.
- **ALLOW THE MOTOR TO COME TO FULL SPEED** prior to starting cut. Starting the cut too soon may cause damage to the machine or blade and/or serious injury.
- **NEVER CUT FERROUS METALS** (Those with any iron or steel content) or masonry. Either of these can cause the carbide tips to fly off the blade at high speeds causing serious injury.
- **DO NOT USE ABRASIVE WHEELS.** The excessive heat and abrasive particles generated by them may damage the saw and cause personal injury.
- **NEVER** have any part of your body in line with the path of the saw blade. Personal injury will occur.
- **NEVER** apply blade lubricant to a running blade. Applying lubricant could cause your hand to move into the blade resulting in serious injury.
- **DO NOT** place either hand in the blade area when the saw is connected to the power source. Inadvertent blade activation may result in serious injury.
- **DO NOT PERFORM FREE-HAND OPERATIONS** (workpiece not supported by table and fence). Hold the work firmly against the fence and table. Free-hand operations on a miter saw could cause the workpiece to be thrown at high speeds, causing serious injury.
- **NEVER REACH AROUND** or behind the saw blade. A blade can cause serious injury.
- **DO NOT** reach underneath the saw unless it is unplugged and turned off. Contact with saw blade may cause personal injury.
- **SECURE THE MACHINE TO A STABLE SUPPORTING SURFACE.** Vibration can possibly cause the machine to slide, walk, or tip over, causing serious injury.
- **USE ONLY CROSSCUT SAW BLADES** recommended for miter saws. For best results, use only zero-degree or negative hook angles when using carbide-tipped blades. Do not use blades with deep gullets. These can deflect and contact the guard, and can cause damage to the machine and/or serious injury.
- **USE ONLY BLADES OF THE CORRECT SIZE AND TYPE** specified for this tool to prevent damage to the machine and/or serious injury.
- **INSPECT BLADE FOR CRACKS** or other damage prior to operation. A cracked or damaged blade can come apart and pieces can be thrown at high speeds, causing serious injury. Replace cracked or damaged blades immediately.
- **CLEAN THE BLADE AND BLADE CLAMPS** prior to operation. Cleaning the blade and blade clamps allows you to check for any damage to the blade or blade clamps. A cracked or damaged blade or blade clamp can come apart and pieces can be thrown at high speeds, causing serious injury.
- **DO NOT** use lubricants or cleaners (particularly spray or aerosol) in the vicinity of the plastic guard. The polycarbonate material used in the guard is subject to attack by certain chemicals.
- **ALWAYS USE THE KERF PLATE AND REPLACE THIS PLATE WHEN DAMAGED.** Small chip accumulation under the saw may interfere with the saw blade or may cause instability of workpiece when cutting.
- **USE ONLY BLADE CLAMPS** specified for this tool to prevent damage to the machine and/or serious injury.
- **CLEAN THE MOTOR AIR SLOTS** of chips and sawdust. Clogged motor air slots can cause the machine to overheat, damaging the machine and possibly causing a short which could cause serious injury.
- **KEEP ARMS, HANDS, AND FINGERS** away from the blade to prevent severe cuts. Clamp all workpieces that would cause your hand to be within 6" of the saw blade.
- **NEVER LOCK THE SWITCH IN THE "ON" position.** Severe personal injury may result.

- **TURN OFF THE MACHINE** and allow the blade to come to a complete stop before raising the arm and prior to cleaning the blade area, removing debris in the path of the blade, before servicing or adjusting tool. A moving blade can cause serious injury.
- **PROPERLY SUPPORT LONG OR WIDE WORKPIECES.** Loss of control of the workpiece can cause injury.
- **NEVER** cross arms in front of blade while using tool. Always make a dry run (unpowered) before making a finish cut so that you can check the path of the blade or severe personal injury may result.
- **ADDITIONAL INFORMATION** regarding the safe and proper operation of power tools (i.e. a safety video) is available from the Power Tool Institute, 1300 Sumner Avenue, Cleveland, OH 44115-2851 (www.powertoolinstitute.com). Information is also available from the National Safety Council, 1121 Spring Lake Drive, Itasca, IL 60143-3201. Please refer to the American National Standards Institute ANSI 01.1 Safety Requirements for Woodworking Machines and the U.S. Department of Labor OSHA 1910.213 Regulations.

⚠ CAUTION: Do not connect unit to electrical power source until complete instructions are read and understood.

⚠ WARNING: Always wear proper personal hearing protection that conforms to ANSI S12.6 (S3.19) during use. Under some conditions and duration of use, noise from this product may contribute to hearing loss.

⚠ WARNING: NEVER MAKE ANY CUT UNLESS THE MATERIAL IS SECURED ON THE TABLE AND AGAINST THE FENCE.

⚠ WARNING: Some dust created by power sanding, sawing, grinding, drilling, and other construction activities contains chemicals known to cause cancer, birth defects or other reproductive harm. Some examples of these chemicals are:

- lead from lead-based paints,
- crystalline silica from bricks and cement and other masonry products, and
- arsenic and chromium from chemically-treated timber (CCA).

Your risk from these exposures varies, depending on how often you do this type of work. To reduce your exposure to these chemicals: work in a well ventilated area, and work with approved safety equipment, such as those dust masks that are specially designed to filter out microscopic particles.

- **Avoid prolonged contact with dust from power sanding, sawing, grinding, drilling, and other construction activities. Wear protective clothing and wash exposed areas with soap and water. Allowing dust to get into your mouth, eyes, or lay on the skin may promote absorption of harmful chemicals.**

⚠ WARNING: Use of this tool can generate and/or disburse dust, which may cause serious and permanent respiratory or other injury. Always use NIOSH/OSHA approved respiratory protection appropriate for the dust exposure. Direct particles away from face and body.

For your convenience and safety, the following warning labels are on your miter saw.

ON MOTOR HOUSING:

⚠ WARNING: FOR YOUR OWN SAFETY, READ INSTRUCTION

MANUAL BEFORE OPERATING SAW.

WHEN SERVICING, USE ONLY IDENTICAL REPLACEMENT PARTS.

DO NOT EXPOSE TO RAIN OR USE IN DAMP LOCATIONS.

ALWAYS WEAR EYE PROTECTION.

ON MOVING FENCES:

ALWAYS ADJUST FENCE PROPERLY BEFORE USE. Clamp small pieces before cutting. See manual.

ON GUARD: DANGER – KEEP AWAY FROM BLADE.

ON UPPER GUARD: PROPERLY SECURE BRACKET WITH BOTH SCREWS BEFORE USE.

ON TABLE: (2 PLACES)

ALWAYS TIGHTEN ADJUSTMENT KNOBS BEFORE USE.

KEEP HANDS 6" FROM PATH OF SAW BLADE.

NEVER PERFORM ANY OPERATION FREEHAND.

NEVER CROSS ARMS IN FRONT OF BLADE.

THINK! YOU CAN PREVENT ACCIDENTS.

DO NOT OPERATE SAW WITHOUT GUARDS IN PLACE.

TURN OFF TOOL, KEEP SAW HEAD DOWN AND WAIT FOR SAW TO STOP BEFORE MOVING HANDS, WORKPIECE OR CHANGING SETTINGS.

UNPLUG TOOL BEFORE CHANGING BLADE, MOVING OR SERVICING UNIT.



DANGER

KEEP AWAY FROM BLADE



Electrical Connection

The electric motor has been designed for one voltage only. Always check that the power supply corresponds to the voltage on the rating plate. 230 V AC means your tool will operate on alternating current. As little as 10% lower voltage can cause loss of power and can result in overheating. All DEWALT tools are factory tested; if this tool does not operate, check the power supply. Your DEWALT tool is double insulated, therefore no earth wire is required.

- **Young children and the infirm.** This appliance is not intended for use by young children or infirm persons without supervision. Young children should be supervised to ensure that they do not play with this appliance
 - This appliance is not intended for use by persons (including children) with reduced physical, sensory or mental capabilities, or lack of experience and knowledge, unless they have been given supervision or instruction concerning use of the appliance by a person responsible for their safety.
 - Children should be supervised to ensure that they do not play with the appliance.
- **Replacement of the supply cord.** If the supply cord is damaged, it must be replaced by the manufacturer or an authorised DEWALT Service Centre in order to avoid a hazard.

Accessories

⚠ WARNING: Since accessories, other than those offered by DEWALT, have not been tested with this product, use of such accessories with this tool could be hazardous. To reduce the risk of injury, only DEWALT, recommended accessories should be used with this product.

If you need any assistance in locating any accessory, please contact: Stanley Black & Decker, 82 Taryn Drive, Epping, VIC 3076 Australia or call 1800 444 224 or (NZ). 0800 339 258.

Description (fig. 1)

- | | | |
|-------------------------------|--------------------------|----------------------------|
| A. Lower guard | M. Fence adjustment knob | Y. XPS™ on/off switch |
| B. Guard bracket screw | N. Fence | Z. Wing nut |
| C. Operating handle | O. Base fence | AA. Depth adjustment screw |
| D. Carrying handle | P. Hand indentation | BB. Depth stop |
| E. Motor housing | Q. Table | CC. Blade wrench |
| F. Motor endcap | R. Bench mounting holes | DD. Base |
| G. Rail lock knob | S. Mitre scale | EE. Bevel lock knob |
| H. Rail set screw adjustment | T. Dust duct inlet | FF. 0° bevel stop |
| I. Head up lock lever release | U. Mitre lock handle | GG. Belt cover |
| J. Rails | V. Mitre latch button | HH. Miter latch override |
| K. Bevel scale | W. Kerf plate | |
| L. Lock down pin | X. Trigger switch | |

FIG. 1

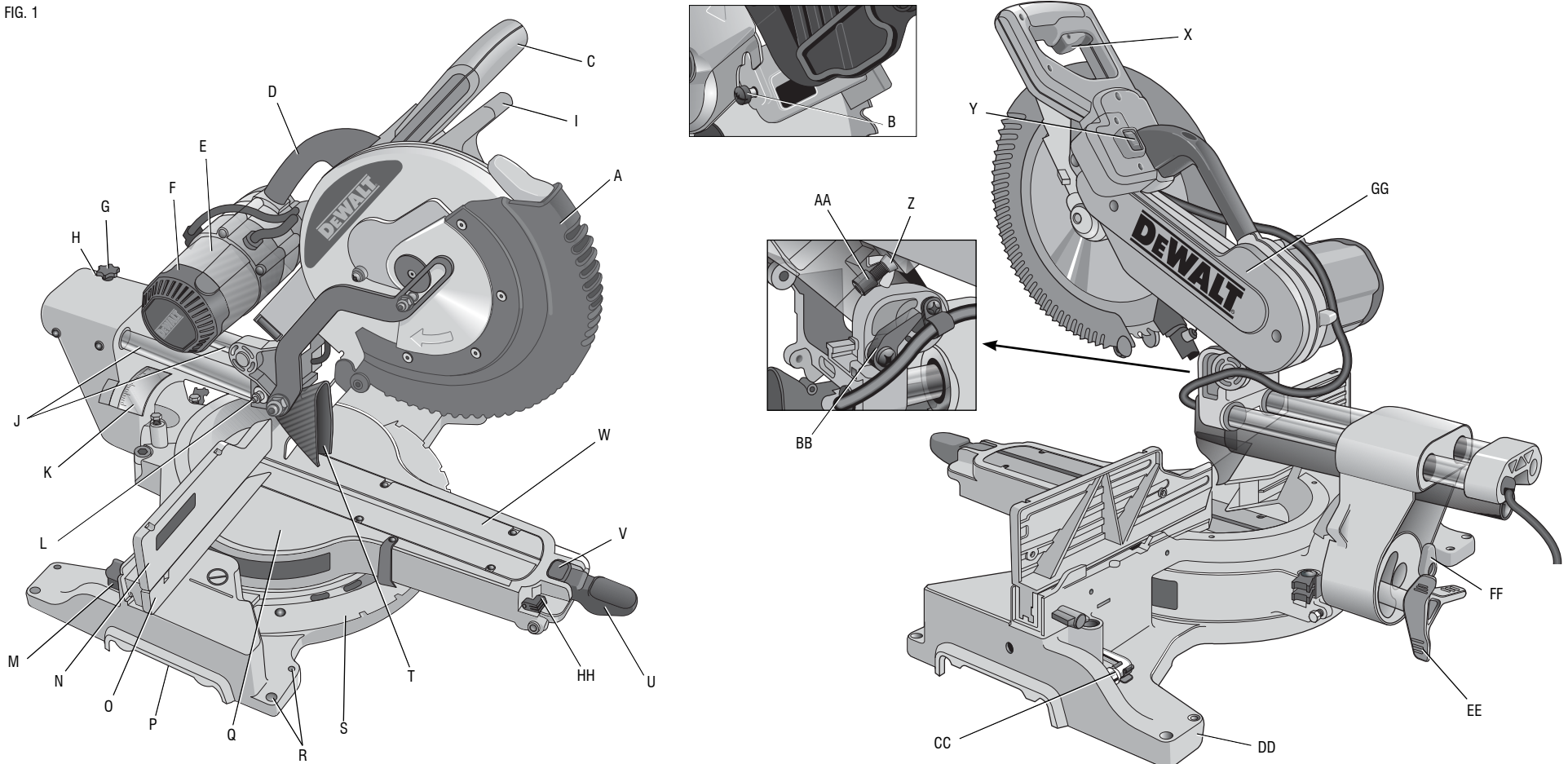

Optional Accessories (fig. 2–8)

The following accessories, designed for your saw, may be helpful. In some cases, other locally obtained work supports, length stops, clamps, etc., may be more appropriate. Use care in selecting and using accessories.

II. DW7080 Extension work support

Used to support long overhanging workpieces, the work support is user assembled. Your saw table is designed to accept two work supports; one on each side.

JJ. DW7051 Adjustable length stop:

Requires the use of one work support (see drawing). It is used to make repetitive cuts of the same length from 0 to 107 cm (42").

KK. DW7082 Workpiece clamp: (similar model included)

Used for firmly clamping workpiece to the saw table for precision cutting.

LL. DW7084 Crown molding fence (Not available in Australia or New Zealand)

Used for precision cutting of crown molding.

MM. DW7053 Dustbag: (Included with some models)

Equipped with a zipper for easy emptying, the dust bag will capture the majority of the sawdust produced (not shown).

NN. DW7023 / DW7033 Leg stand

The leg stand is used to extend the table width of the saw.

OO. DW7025 Clamp brackets

The clamp brackets are used for mounting the saw to a stand.

SAW BLADES: ALWAYS USE 305 mm (12") SAW BLADES WITH EITHER 1" (25.4 mm) OR 5/8" (15.88 mm) ARBOR HOLES. SPEED RATING MUST BE AT LEAST 4800 RPM. Never use a smaller diameter blade. It will not be guarded properly. Use crosscut blades only! Do not use blades designed for ripping, combination blades or blades with hook angles in excess of 7°.

BLADE DESCRIPTIONS		
APPLICATION	DIAMETER	TEETH
Construction Saw Blades (<i>thin kerf with anti-stick rim</i>)		
General Purpose	305 mm (12")	40
Fine Crosscuts	305 mm (12")	60
Woodworking Saw Blades (<i>provide smooth, clean cuts</i>)		
Fine crosscuts	305 mm (12")	80
Non-ferrous metals	305 mm (12")	96

NOTE: For cutting non-ferrous metals, use only saw blades with TCG (Triple Chip Grind) teeth designed for this purpose.

Unpacking Your Saw

Check the contents of your miter saw carton to make sure that you have received all parts. In addition to this instruction manual, the carton should contain:

- 1 DWS780 miter saw
- 1 DeWALT 305 mm (12") diameter saw blade

In bag:

- 1 Blade wrench
- 1 DW7053 dustbag
- 1 Material clamp

Specifications

CAPACITY OF CUT

50° miter left, 60° miter right,
49° bevel left and right

FIG. 2

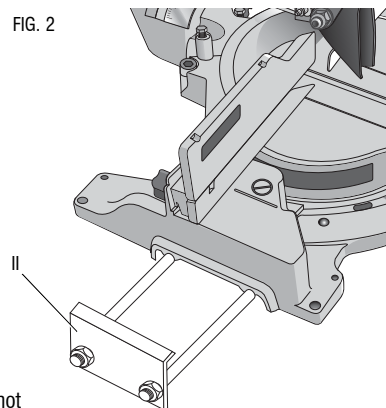

FIG. 3

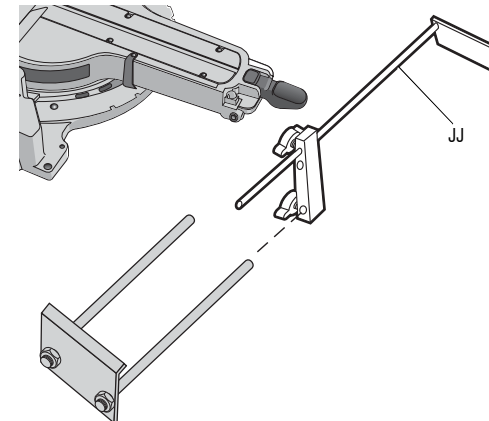

FIG. 4

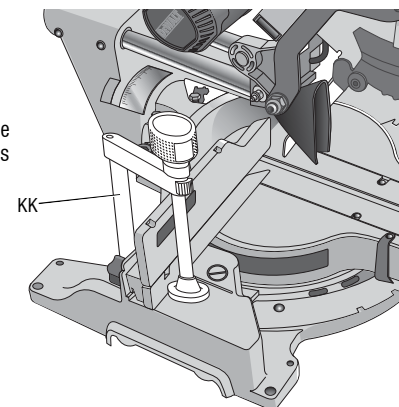

FIG. 5

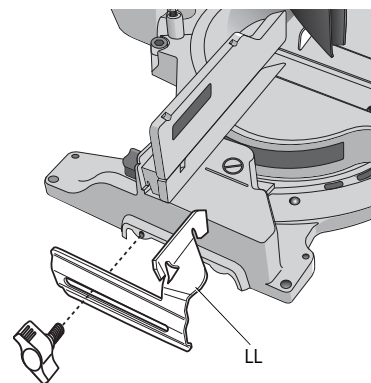

FIG. 6

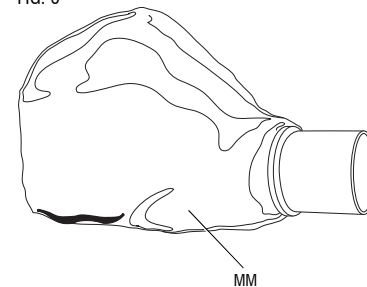

FIG. 7

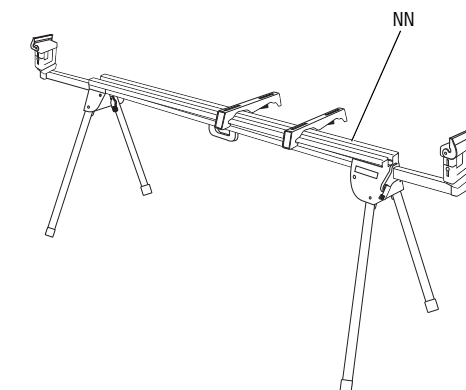
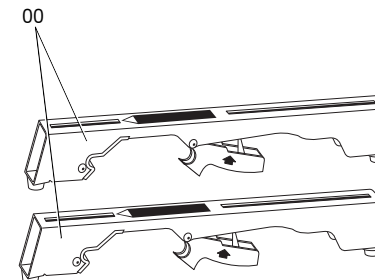

FIG. 8



ANGLE	MAXIMUM CAPACITY OF CUT		RESULT	
	0° miter	Height	112 mm (4.4")	Width
Width		349 mm (13.75")	Height	76 mm (3.0")
45° miter	Height	112 mm (4.4")	Width	147 mm (5.8")
	Width	244 mm (9.6")	Height	76 mm (3.0")
45° bevel – left	Height	79 mm (3.1")	Width	290 mm (11.4")
	Width	349 mm (13.75")	Height	43 mm (1.7")
45° bevel – right	Height	56 mm (2.2")	Width	290 mm (11.4")
	Width	349 mm (13.75")	Height	28 mm (1.1")

Your saw is capable of cutting baseboard moldings held vertically 20 mm (0.8") thick by 171 mm (6.75") tall on a 45° right or left miter, when using the slide lock lever (Fig. 13).

NOTE: Your saw is capable of cutting the following once a special setup procedure is followed. Refer to **Special Cuts**.

0° miter	Height 38 mm (1.5")	Width 409 mm (16.1")
45° miter	Height 38 mm (1.5")	Width 297 mm (11.7")

DRIVE

230 volt motor

1675 watts in	7.5 amp motor
3800 RPM	Cut helical gears
Multi-V belt	Roller bearings
Automatic electric brake	Carbide blade

Familiarization (fig. 1, 9)

Your miter saw is fully assembled in the carton.

Examine figure 1 to become familiar with the saw and its various parts. The section on adjustments will refer to these terms and you must know what and where the parts are.

CAUTION: Risk of personal injury. Keep thumb underneath handle when pulling handle down otherwise thumb may be pinched between handle and moving lower guard. The handle is placed close to the guard for special cuts.

1. Open the box and lift the saw out by the convenient carrying handle (D), as shown in figure 9.
2. Place the saw on a smooth, flat surface.
3. Release the rail lock knob (G), and push the saw head back to lock it in the rear position.
4. Press down lightly on the operating handle (C) and pull out the lock down pin (L).
5. Gently release the downward pressure and hold the operating handle, allowing it to rise to its full height.

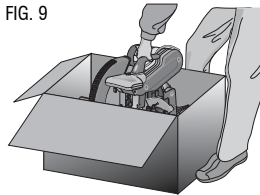

Bench Mounting (fig. 1)

Holes (R) are provided in all four feet to facilitate bench mounting. Two different-sized holes are provided to accommodate different sizes of screws. Use either hole; it is not necessary to use both.

Always mount your saw firmly to a stable surface to prevent movement. To enhance the tool's portability, it can be mounted to a piece of 12.7 mm (1/2") or thicker plywood which can then be clamped to your work support or moved to other job sites and reclamped.

NOTE: If you elect to mount your saw to a piece of plywood, make sure that the mounting screws don't protrude from the bottom of the wood. The plywood must sit flush on the work support. When clamping the saw to any work surface, clamp only on the clamping bosses where the mounting screw holes are located. Clamping at any other point will interfere with the proper operation of the saw.

CAUTION: To prevent binding and inaccuracy, be sure the mounting surface is not warped or otherwise uneven. If the saw rocks on the surface, place a thin piece of material under one saw foot until the saw sits firmly on the mounting surface.

Changing or Installing a New Saw Blade (Fig. 10A-10C)

WARNING: To reduce the risk of serious personal injury, turn off the tool and disconnect it from the power source before attempting to move it, change accessories or make any adjustments.

CAUTION:

- Never depress the spindle lock button while the blade is under power or coasting.
- Do not cut ferrous metal (containing iron or steel) or masonry or fiber cement product with this miter saw.

NOTE: The blade guard on your saw will automatically raise when the head up-lock release lever (i) is pushed and the arm is brought down; it will lower over the blade as the arm is raised.

REMOVING THE BLADE

1. Unplug the saw.
2. Raise the arm to the upper position and raise the lower guard (A) as far as possible.
3. Loosen, but do not remove guard bracket screw (B) until the bracket can be raised far enough to access the blade screw (PP). Lower guard will remain raised due to the position of the guard bracket screw.

FIG. 10A

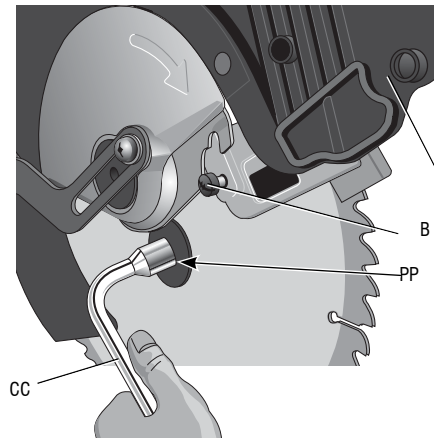
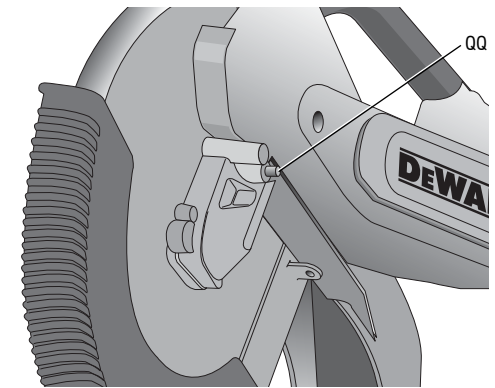

FIG. 10B



4. Depress the spindle lock button (QQ) while carefully rotating the saw blade by hand until the lock engages.
5. Keeping the button depressed, use the other hand and the wrench provided (CC) to loosen the blade screw.
6. Remove the blade screw (PP), outer clamp washer (RR), blade (SS) and blade adapter (I), if used. The inner clamp washer (TT) may be left on the spindle.

NOTE: For blades with a blade hole of 15.88 mm (5/8"), the 25.4 mm (1") blade adapter (I) is not used.

INSTALLING A BLADE

1. Unplug the saw.
2. With the arm raised, the lower guard held open and the guard bracket raised, place the blade on the spindle, onto the blade adapter (if using a blade with a 1" [25.4 mm] diameter blade hole) and against the inner blade clamp with the teeth at the bottom of the blade pointing toward the back of the saw.
3. Assemble the outer clamp washer onto the spindle.
4. Install the blade screw and, engaging the spindle lock, tighten the screw firmly with wrench provided (turn counterclockwise, left-hand threads).

FIG. 10C

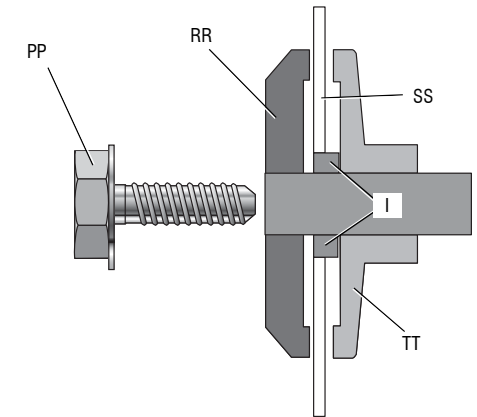

NOTE: When using blades with a 5/8" (15.88 mm) diameter blade hole, the blade adapter will not be used and should be stored in a safe place for future use. The separate blade adapter is not available on all models.

- Return the guard bracket to its original position and firmly tighten the guard bracket screw to hold bracket in place.

▲ WARNING:

- **The guard bracket must be returned to its original position and the guard bracket screw tightened before activating the saw.**
- **Failure to do so may allow the guard to contact the spinning saw blade resulting in damage to the saw and severe personal injury.**

Transporting the Saw (fig. 1)

▲ WARNING: To reduce the risk of serious personal injury, ALWAYS lock the rail lock knob, mitre lock handle, bevel lock handle, lock down pin and fence adjustment knobs before transporting saw.

In order to conveniently carry the mitre saw, a carrying handle (D) has been included on the top of the saw arm.

- To transport the saw, lower the head and depress the lock down pin (L).
- Lock the rail lock knob with the saw head in the front position, lock the mitre arm in the full left mitre angle, slide the fence (N) completely inward and lock the bevel lock knob (EE) with the saw head in the vertical position to make the tool as compact as possible.
- Always use the carrying handle (D) or the hand indentations (P).

Features and Controls

▲ WARNING: To reduce the risk of serious personal injury, turn off the tool and disconnect it from the power source before attempting to move it, change accessories or make any adjustments.

MITRE CONTROL (FIG. 11)

The mitre lock handle (U) and mitre latch button (V) allow you to mitre your saw to 60° right and 50° left. To mitre the saw, lift the mitre lock handle, push the mitre latch button and set the mitre angle desired on the mitre scale (S). Push down on the mitre lock handle to lock the mitre angle.

MITER LATCH OVERRIDE (FIG. 11)

The miter latch override (HH) allows your saw to override the common stop angles. To override the common stop angles, push the miter latch override button and flip the miter latch override lever to the vertical position.

BEVEL LOCK KNOB (FIG. 1)

The bevel lock allows you to bevel the saw 49° left or right. To adjust the bevel setting, turn the knob (EE) counterclockwise. The saw head bevels easily to the left or to the right once the 0° bevel override knob is pulled. To tighten, turn the bevel lock knob clockwise.

0° BEVEL OVERRIDE (FIG. 1)

The bevel stop override (FF) allows you to bevel the saw to the right past the 0° mark.

When engaged, the saw will automatically stop at 0° when brought up from the left. To temporarily move past 0° to the right, pull the bevel lock knob (EE). Once the knob is released, the override will be reengaged. The bevel lock knob can be locked out by twisting the knob 180°.

FIG. 11

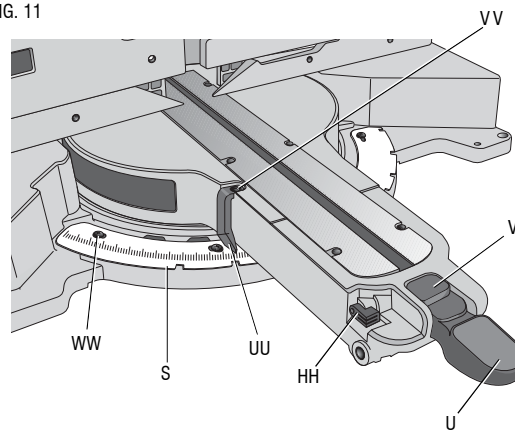

FIG. 12

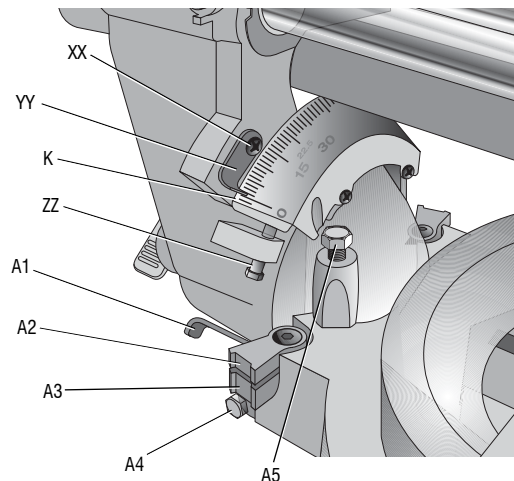
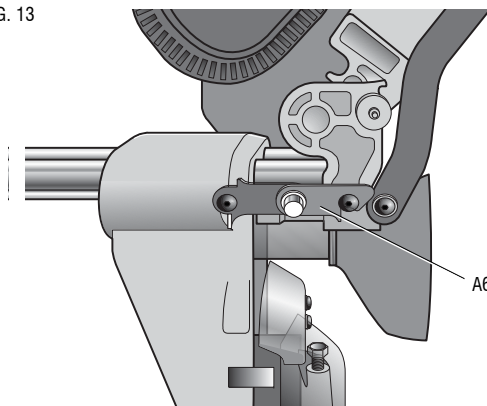

FIG. 13



When at 0°, the override locks in place. To operate the override, bevel the saw slightly to the left.

45° BEVEL STOP OVERRIDE (FIG. 12)

There are two bevel stop override levers, one on each side of the saw. To bevel the saw, left or right, past 45°, push the 45° bevel override lever (A1) rearward. When in the rearward position, the saw can bevel past these stops. When the 45° stops are needed, pull the 45° bevel override lever forward.

CROWN BEVEL PAWLS (FIG. 12)

When cutting crown molding laying flat, your saw is equipped to accurately and rapidly set a crown stop, left or right (refer to **Instructions for Cutting Crown Molding Laying Flat and Using the Compound Features**). The crown bevel pawl (A3) can be rotated to contact the crown adjustment screw.

To reverse the crown bevel pawl, remove the retaining screw, the 22.5° bevel pawl (A2) and the 33.86° crown bevel pawl (A3). Flip the crown bevel pawl (A3) so the 30° text is facing up. Reattach the screw to secure the 22.5° bevel pawl and the crown bevel pawl. The accuracy setting will not be affected.

22.5° BEVEL PAWLS (FIG. 12)

Your saw is equipped to rapidly and accurately set a 22.5° bevel, left or right. The 22.5° bevel pawl (A2) can be rotated to contact the crown adjustment screw (ZZ).

RAIL LOCK KNOB (FIG. 1)

The rail lock knob (G) allows you to lock the saw head firmly to keep it from sliding on the rails (J). This is necessary when making certain cuts or when transporting the saw.

DEPTH STOP (FIG. 1)

The depth stop (BB) allows the depth of cut of the blade to be limited. The stop is useful for applications such as grooving and tall vertical cuts. Rotate the depth stop forward and adjust the depth adjustment screw (AA) to set the desired depth of cut. To secure the adjustment, tighten the wing nut (Z). Rotating the depth stop to the rear of the saw will bypass the depth stop feature. If the depth adjustment screw is too tight to loosen by hand, the provided blade wrench (CC) can be used to loosen the screw.

LOCK DOWN PIN (FIG. 1)

▲ WARNING: The lock down pin should be used ONLY when carrying or storing the saw. NEVER use the lock down pin for any cutting operation. To lock the saw head in the down position, push the saw head down, push the lock down pin (L) in and release the saw head. This will hold the saw head safely down for moving the saw from place to place. To release, press the saw head down and pull the pin out.

SLIDE LOCK LEVER (FIG. 13, 23)

The slide lock lever (A6) places the saw in a position to maximize cutting of base molding when cut vertically as shown in figure 23.

Adjustment

Your mitre saw is fully and accurately adjusted at the factory at the time of manufacture. If readjustment due to shipping and handling or any other reason is required, follow the instructions below to adjust your saw. Once made, these adjustments should remain accurate.

MITRE SCALE ADJUSTMENT (FIG. 11, 14)

1. Unlock the mitre lock handle (U) and swing the mitre arm until the mitre latch button (V) locks it at the 0° mitre position. Do not lock the mitre lock handle.

- Place a square against the saw's fence and blade, as shown. (Do not touch the tips of the blade teeth with the square. To do so will cause an inaccurate measurement.)
- If the saw blade is not exactly perpendicular to the fence, loosen the four screws (WW) that hold the mitre scale (S) and move the mitre lock handle and the scale left or right until the blade is perpendicular to the fence, as measured with the square.
- Retighten the four screws. Pay no attention to the reading of the mitre pointer (UU) at this time.

MITRE POINTER ADJUSTMENT (FIG. 11)

- Unlock the mitre lock handle (U) to move the mitre arm to the zero position.
- With the mitre lock handle unlocked, allow the mitre latch to snap into place as you rotate the mitre arm to zero.
- Observe the mitre pointer (UU) and mitre scale (S) shown in figure 11. If the pointer does not indicate exactly zero, loosen the mitre pointer screw (V V) holding the pointer in place, reposition the pointer and tighten the screw.

BEVEL SQUARE TO TABLE ADJUSTMENT (FIG. 1, 12, 15)

- To align the blade square to the table, lock the arm in the down position with the lock down pin (L).
- Place a square against the blade, ensuring the square is not on top of a tooth.
- Loosen the bevel lock knob (EE) and ensure the arm is firmly against the 0° bevel stop.
- Rotate the 0° bevel adjustment screw (A5) with the 13 mm (1/2") blade wrench (CC) as necessary so that the blade is at 0° bevel to the table.

BEVEL POINTER ADJUSTMENT (FIG. 12)

If the bevel pointers (YY) do not indicate zero, loosen each screw (XX) that holds each bevel pointer in place and move them as necessary. Ensure the 0° bevel is correct and the bevel pointers are set before adjusting any other bevel angle screws.

BEVEL STOP 45° RIGHT AND LEFT ADJUSTMENT (FIG. 1, 12)

To adjust the right 45° bevel stop:

- Loosen the bevel lock knob (EE) and pull the 0° bevel stop (FF) to override the 0° bevel stop.
- When the saw is fully to the right, if the bevel pointer (YY) does not indicate exactly 45°, turn the left 45° bevel adjustment screw (A4) with the 13 mm (1/2") blade wrench (CC) until the bevel pointer indicates 45°.

To adjust the left 45° bevel stop:

- Loosen the bevel lock knob and tilt the head to the left.
- If the bevel pointer does not indicate exactly 45°, turn the right 45° bevel adjustment screw until the bevel pointer reads 45°.

ADJUSTING THE BEVEL STOP TO 22.5° (OR 30°) (FIG. 2, 12)

NOTE: Adjust the bevel angles only after performing the 0° bevel angle and bevel pointer adjustment.

To set the left 22.5° bevel angle, flip out the left 22.5° bevel pawl (A2). Loosen the bevel lock knob (EE) and tilt the head fully to the left. If the bevel pointer (YY) does not indicate exactly 22.5°, turn the crown adjustment screw (ZZ) contacting the pawl with a 10 mm (7/16") wrench until the bevel pointer reads 22.5°.

To adjust the right 22.5° bevel angle, flip out the right 22.5° bevel pawl. Loosen the bevel lock knob and pull the 0° bevel stop (FF) to override the 0° bevel stop. When the saw is fully to the right, if the bevel pointer does

FIG. 14

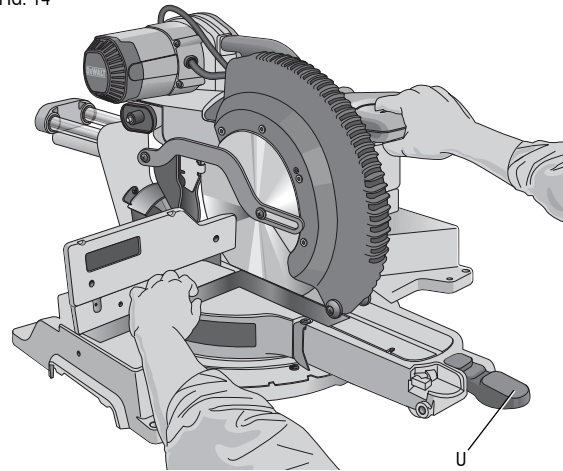

FIG. 15

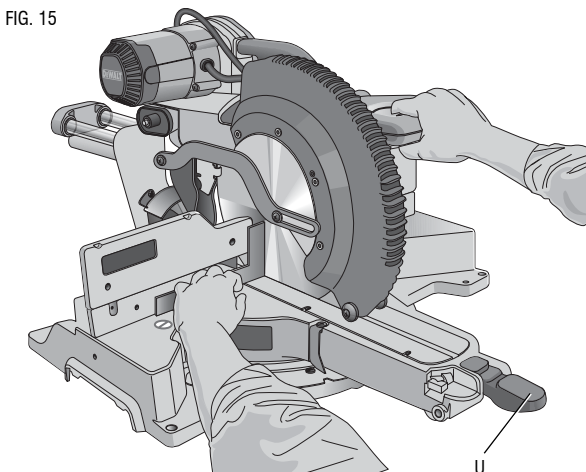
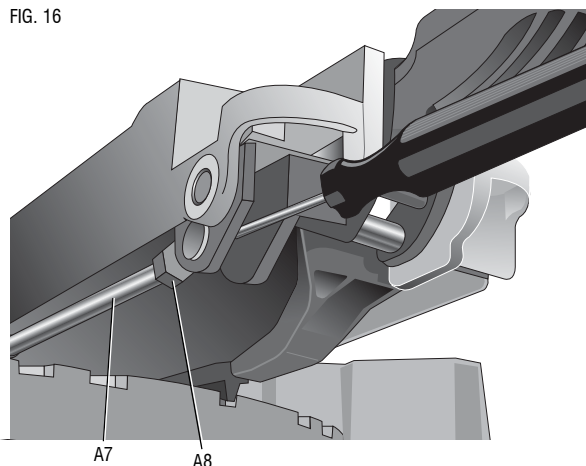

FIG. 16



not indicate exactly 22.5°, turn the crown adjustment screw contacting the pawl with a 10 mm (7/16") wrench until the bevel pointer indicates exactly 22.5°.

FENCE ADJUSTMENT (FIG. 1)

The upper part of the fence can be adjusted to provide clearance, allowing the saw to bevel to a full 49° both left and right.

- To adjust each fence (N), loosen the fence adjustment knob (M) and slide the fence outward.
- Make a dry run with the saw turned off and check for clearance.
- Adjust the fence to be as close to the blade as practical to provide maximum workpiece support, without interfering with arm up and down movement.
- Tighten the fence adjustment knob securely.
- When the bevel operations are complete, relocate the fence.

For certain cuts, it may be desirable to bring the fences closer to the blade. To do so, back the fence adjustment knobs (M) out two turns and move the fences closer to the blade past the normal limit, then tighten the fence adjustment knobs. Make a dry cut first to ensure the blade does not contact the fences.

NOTE: The tracks of the fences can become clogged with sawdust. Use a brush or some low pressure air to clear the guide grooves.

GUARD ACTUATION AND VISIBILITY (FIG. 1)

The lower guard (A) on your saw has been designed to automatically uncover the blade when the arm is brought down and to cover the blade when the arm is raised.

The guard can be raised by hand when installing or removing saw blades or for inspection of the saw. **NEVER RAISE THE LOWER GUARD MANUALLY UNLESS THE BLADE IS STOPPED.**

KERF PLATE ADJUSTMENT (FIG. 1)

To adjust the kerf plates (W), loosen the screws holding the kerf plates in place. Adjust so that the kerf plates are as close as possible without interfering with the blade's movement.

If a zero kerf width is desired, adjust the kerf plates as close to each other as possible. They can now be cut slowly with the saw blade to give the smallest gap possible between the blade and the kerf plates.

RAIL GUIDE ADJUSTMENT (FIG. 1)

Regularly check the rails (J) for play or clearance.

The right rail can be adjusted with the set screw (H). To reduce clearance, use a 4 mm hex wrench and rotate the set screw clockwise gradually while sliding the saw head back and forth.

MITRE LOCK ADJUSTMENT (FIG. 1, 16)

The mitre lock rod (A7) should be adjusted if the table of the saw can be moved when the mitre lock handle is locked (down).

- Put the mitre lock handle (U) in the unlocked (up) position.
- Using a 13 mm (1/2") open end wrench, loosen the lock nut (A8) on the mitre lock rod.
- Using a slotted screwdriver, tighten the mitre lock rod by turning it clockwise as shown in figure 16. Turn the lock rod until it is snug, then turn counterclockwise one turn.
- Re-lock the mitre lock to a non-detented measurement on the mitre scale – for example, 34° – and make sure the table will not rotate.
- Tighten lock nut.

Prior to Operation

- Install the appropriate saw blade. Do not use excessively worn blades. The maximum rotation speed of the tool must not exceed that of the saw blade. Do not use any abrasive blades.

- Do not attempt to cut excessively small pieces.
- Allow the blade to cut freely. Do not force.
- Allow the motor to reach full speed before cutting.
- Make sure all locking knobs and clamp handles are tight.
- Secure the workpiece.
- Although this saw will cut wood and many nonferrous materials, these operating instructions refer to the cutting of wood only. The same guidelines apply to the other materials. Do not cut ferrous (iron and steel) materials, fibre cement or masonry with this saw!
- Make sure to use the kerf plate. Do not operate the machine if the kerf slot is wider than 10 mm.

OPERATION

Instructions for Use

▲WARNING: Always observe the safety instructions and applicable regulations.

▲WARNING: To reduce the risk of serious personal injury, turn off the tool and disconnect it from the power source before attempting to move it, change accessories or make any adjustments.

Refer to **Saw Blades** under **Optional Accessories** to select the blade that best fits your needs.

Ensure the machine is placed to satisfy your ergonomic conditions in terms of table height and stability. The machine site shall be chosen so that the operator has a good overview and enough free surrounding space around the machine that allows handling of the workpiece without any restrictions.

To reduce effects of vibration make sure the environment temperature is not too cold, the machine and accessories are well maintained and the workpiece size is suitable for this machine.

Plug the saw into any household 60 Hz power source. Refer to the nameplate for voltage. Be sure the cord will not interfere with your work.

Proper Body and Hand Position (fig. 17A, 17B)

▲WARNING: To reduce the risk of serious personal injury, ALWAYS use proper hand position as shown in fig. 17A.

▲WARNING: To reduce the risk of serious personal injury, ALWAYS hold securely in anticipation of a sudden reaction.

- Never place hands near cutting area. Place hands no closer than 152 mm (6") from the blade.
- Hold the workpiece tightly to the table and the fence when cutting. Keep hands in position until the trigger has been released and the blade has completely stopped.
- ALWAYS MAKE DRY RUNS (UNPOWERED) BEFORE FINISH CUTS SO THAT YOU CAN CHECK THE PATH OF THE BLADE. DO NOT CROSS HANDS, AS SHOWN IN Figure 17B.
- Keep both feet firmly on the floor and maintain proper balance. As you move the mitre arm left and right, follow it and stand slightly to the side of the saw blade.
- Sight through the guard louvers when following a pencil line.

Switching On and Off (fig. 1)

To turn the saw on, depress the trigger switch (X). To turn the tool off, release the trigger switch.

Allow the blade to spin up to full operating speed before making the cut. Release the trigger switch and allow the brake to stop the blade before raising the saw head.

A hole is provided in the trigger switch for insertion of a padlock to lock the saw off.

FIG. 17A

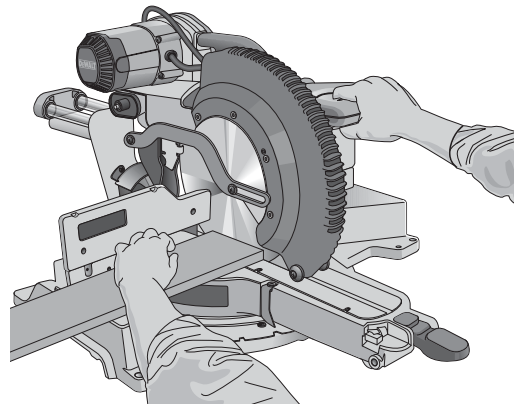

FIG. 18

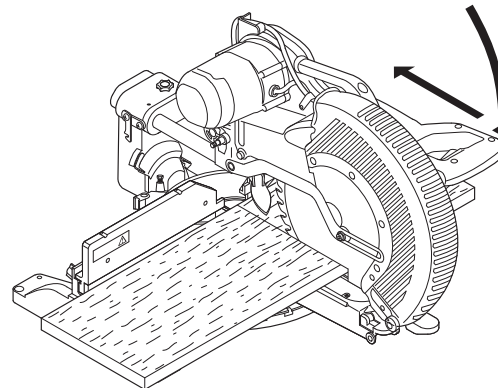

FIG. 17B

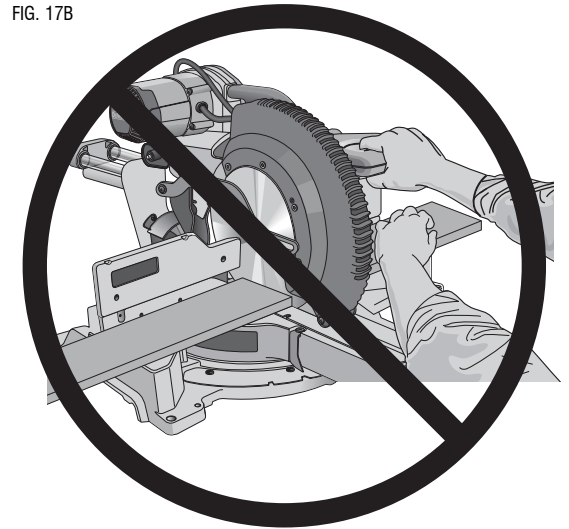
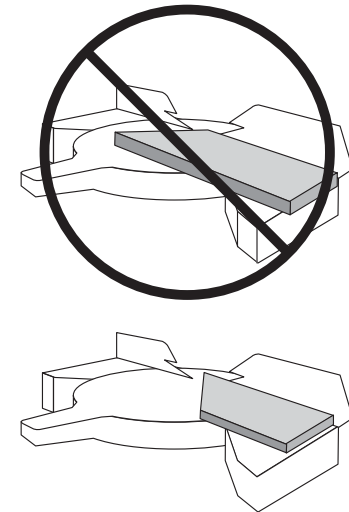

FIG. 19



Use of XPS™ LED Worklight System (fig. 1)

NOTE: The mitre saw must be connected to a power source. The XPS™ LED Worklight System is equipped with an on/off switch (Y). The XPS™ LED Worklight System is independent of the mitre saw's trigger switch. The light does not need to be on in order to operate the saw.

To cut through an existing pencil line on a piece of wood:

1. Turn on the XPS™ system, then pull down on the operating handle (C) to bring the saw blade close to the wood. The shadow of the blade will appear on the wood.
2. Align the pencil line with the edge of the blade's shadow. You may have to adjust the mitre or bevel angles in order to match the pencil line exactly.

Basic Saw Cuts (fig. 1, 18, 19)

If the slide feature is not used, ensure the saw head is pushed back as far as possible and the rail lock knob (G) is tightened. This will prevent the saw from sliding along its rails as the workpiece is engaged.

Cutting of multiple pieces is not recommended but can be done safely by ensuring that each piece is held firmly against the table and fence.

STRAIGHT VERTICAL CROSSCUT

1. Set and lock the mitre arm at zero, and hold the wood firmly on the table (Q) and against the fence (N).
2. With the rail lock knob (G) tightened, turn on the saw by squeezing the trigger switch (X).

- When the saw comes up to speed, lower the arm smoothly and slowly to cut through the wood. Let the blade come to a full stop before raising arm.

SLIDING CROSSCUT

When cutting anything larger than a 51 x 150 mm (2" x 6" [51 x 105 mm (2" x 4") at 45° mitre]) workpiece, use an out-down-back motion with the rail lock knob (G) loosened (Fig. 18).

Pull the saw out toward you, lower the saw head down toward the workpiece, and slowly push the saw back to complete the cut.

Do not allow the saw to contact the top of the workpiece while pulling out. The saw may run toward you, possibly causing personal injury or damage to the workpiece.

MITRE CROSSCUT

The mitre angle is often 45° for making corners, but can be set anywhere from zero to 50° left or 60° right. Proceed as for a straight vertical crosscut.

When performing a mitre cut on workpieces wider than 51 x 105 mm (2" x 4") that are shorter in length, always place the longer side against the fence (Fig. 19).

BEVEL CUT

Bevel angles can be set from 49° right to 49° left and can be cut with the mitre arm set between 50° left or 60° right. Refer to the **Features and Controls** section for detailed instructions on the bevel system.

- Loosen the bevel lock (EE), and move the saw to the left or right as desired. It is necessary to move the fence (N) to allow clearance. Tighten the fence adjustment knob (M) after positioning the fences.
- Tighten the bevel lock firmly.

At some extreme angles, the right or left side fence might have to be removed. Refer to **Fence Adjustment** in the **Adjustments** section for important information on adjusting the fences for certain bevel cuts.

To remove the left or right fence, unscrew the fence adjustment knob (M) several turns and slide the fence out.

GROOVING (FIG. 1)

Your saw is equipped with a depth stop (BB), depth adjustment screw (AA) and wing nut (Z) to allow for groove cutting.

- Flip the depth stop (BB) towards the front of the saw.
- Adjust the wing nut (Z) and depth adjustment screw (AA) to set the depth of the groove cut.
- Place a piece of scrap material of approx. 5 cm between fence and workpiece in order to perform a straight groove cut.

QUALITY OF CUT

The smoothness of any cut depends on a number of variables, such as the material being cut, blade type, blade sharpness and rate of cut.

When smoothest cuts are desired for molding and other precision work, a sharp (60 tooth carbide) blade and a slower, even cutting rate will produce the desired results.

⚠ WARNING: Ensure that the material does not move or creep while cutting; clamp it securely in place. Always let the blade come to a full stop before raising arm. If small fibers of wood still split out at the rear of the workpiece, stick a piece of masking tape on the wood where the cut will be made. Saw through the tape and carefully remove tape when finished.

Clamping the Workpiece (fig. 4)

⚠ WARNING: A workpiece that is clamped, balanced and secure before a cut may become unbalanced after a cut is completed. An unbalanced load may tip the saw or anything the saw is attached to, such as a table

FIG. 20

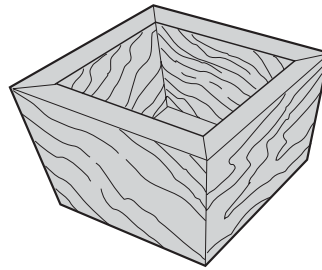

FIG. 21

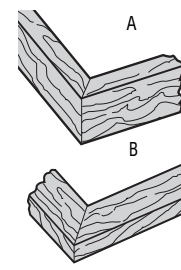
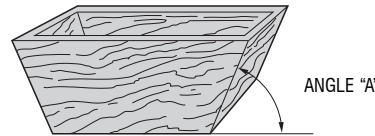

FIG. 22



or workbench. When making a cut that may become unbalanced, properly support the workpiece and ensure the saw is firmly bolted to a stable surface. Personal injury may occur.

⚠ WARNING: The clamp foot must remain clamped above the base of the saw whenever the clamp is used. Always clamp the workpiece to the base of the saw – not to any other part of the work area. Ensure the clamp foot is not clamped on the edge of the base of the saw.

⚠ CAUTION: Always use a work clamp to maintain control and reduce the risk of workpiece damage and personal injury, if your hands are required to be within 152 mm (6") of the blade during the cut.

Use the material clamp (KK) provided with your saw. Other aids such as spring clamps, bar clamps or C-clamps may be appropriate for certain sizes and shapes of material. The left or right fence will slide from side to side to aid in clamping.

TO INSTALL CLAMP

- Insert it into the hole behind the fence. The clamp should be facing toward the back of the mitre saw. The groove on the clamp rod should be fully inserted into the base. Ensure this groove is fully inserted into the base of the mitre saw. If the groove is visible, the clamp will not be secure.
- Rotate the clamp 180° toward the front of the mitre saw.
- Loosen the knob to adjust the clamp up or down, then use the fine adjust knob to firmly clamp the workpiece.

NOTE: Place the clamp on the opposite side of the base when beveling. ALWAYS MAKE DRY RUNS (UNPOWERED) BEFORE FINISH CUTS TO CHECK THE PATH OF THE BLADE. ENSURE THE CLAMP DOES NOT INTERFERE WITH THE ACTION OF THE SAW OR GUARDS.

⚠ WARNING: Always use a material clamp when cutting non-ferrous metals.

Support for Long Pieces (fig. 7)

ALWAYS SUPPORT LONG PIECES.

For best results, use the DW7023 or DW7033 leg stands (NN) to extend the table width of your saw. Support long workpieces using any convenient means such as sawhorses or similar devices to keep the ends from dropping.

Cutting Picture Frames, Shadow Boxes And Other Four-Sided Projects (fig. 20, 21)

Try a few simple projects using scrap wood until you develop a “feel” for your saw. Your saw is the perfect tool for mitring corners like the one shown in figure 20.

Sketch A in figure 21 shows a joint made with the bevel adjustment method. The joint shown can be made using either method.

- Using bevel adjustment:
 - The bevel for the two boards is adjusted to 45° each, producing a 90° corner.
 - The mitre arm is locked in the zero position and the bevel adjustment is locked at 45°.
 - The wood is positioned with the broad flat side against the table and the narrow edge against the fence.
- Using mitre adjustment:
 - The same cut can be made by mitring right and left with the broad surface against the fence.

Cutting Trim Molding And Other Frames (fig. 21)

Sketch B in figure 21 shows a joint made by setting the mitre arm at 45° to mitre the two boards to form a 90° corner. To make this type of joint, set the bevel adjustment to zero and the mitre arm to 45°. Once again, position the wood with the broad flat side on the table and the narrow edge against the fence.

The two sketches in figure 21 are for four-sided objects only. As the number of sides changes, so do the mitre and bevel angles. The chart below gives the proper angles for a variety of shapes, assuming that all sides are of equal length.

NUMBER OF SIDES	MITRE OR BEVEL ANGLE
4	45°
5	36°
6	30°
7	25.7°
8	22.5°
9	20°
10	18°

For a shape that is not shown in the chart, use the following formula: 180° divided by the number of sides equals the mitre (if the material is cut vertically) or bevel angle (if the material is cut laying flat).

Cutting Compound Mitres (fig. 22)

A compound mitre is a cut made using a mitre angle and a bevel angle at the same time. This is the type of cut used to make frames or boxes with slanting sides like the one shown in figure 22.

⚠ WARNING: If the cutting angle varies from cut to cut, check that the bevel lock knob and the mitre lock handle are securely locked. These must be locked after making any changes in bevel or mitre.

The chart (Table 1) found in the back of this manual will assist you in selecting the proper bevel and mitre settings for common compound mitre cuts.

- Select the desired angle A (fig. 22) of your project and locate that angle on the appropriate arc in the chart.
- From that point follow the chart straight down to find the correct bevel angle and straight across to find the correct mitre angle.

- Set your saw to the prescribed angles and make a few trial cuts. Practise fitting the cut pieces together.

Example: To make a 4-sided box with 26° exterior angles (Angle A, fig. 22), use the upper right arc. Find 26° on the arc scale. Follow the horizontal intersecting line to either side to get mitre angle setting on saw (42°). Likewise, follow the vertical intersecting line to the top or bottom to get the bevel angle setting on the saw (18°). Always try cuts on a few scrap pieces of wood to verify the settings on the saw.

Cutting Base Moulding (Fig. 13, 23)

- Straight 90° cuts:
 - Position the wood against the fence and hold it in place as shown in figure 23. Turn on the saw, allow the blade to reach full speed and lower the arm smoothly through the cut.

CUTTING BASE MOULDING FROM 76 mm UP TO 171 mm (3" UP TO 6.75") HIGH VERTICALLY AGAINST THE FENCE

NOTE: Use the slide lock lever (A6), shown in Figure 13, when cutting base moulding measuring from 76 mm to 171 mm (3" to 6.75") high vertically against the fence.

Position material as shown in figure 23.

All cuts should be made with the back of the moulding against the fence and with the bottom of the moulding against the table.

	INSIDE CORNER	OUTSIDE CORNER
Left side	Mitre left 45° Save left side of cut	Mitre right 45° Save left side of cut
Right side	Mitre right 45° Save right side of cut	Mitre left 45° Save right side of cut

Material up to 171 mm (6.75") can be cut as described above.

FIG. 23

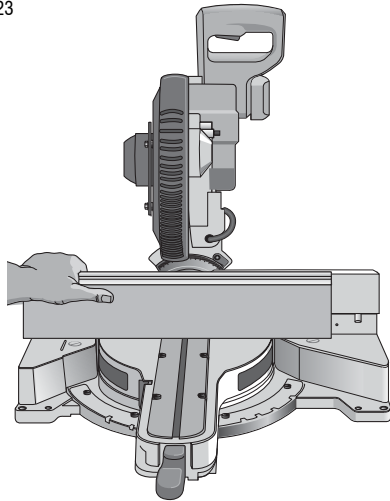

FIG. 24A

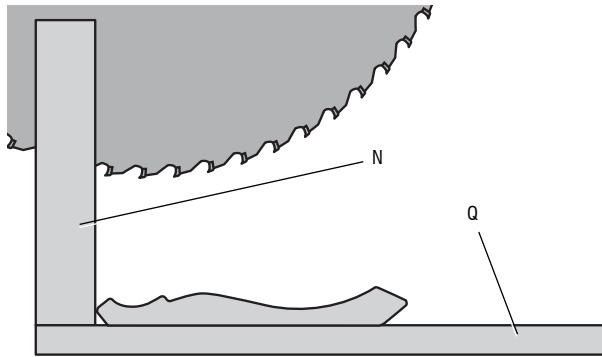

FIG. 25A

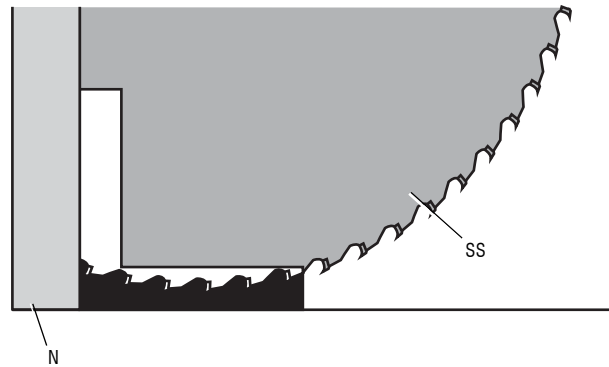

FIG. 24B

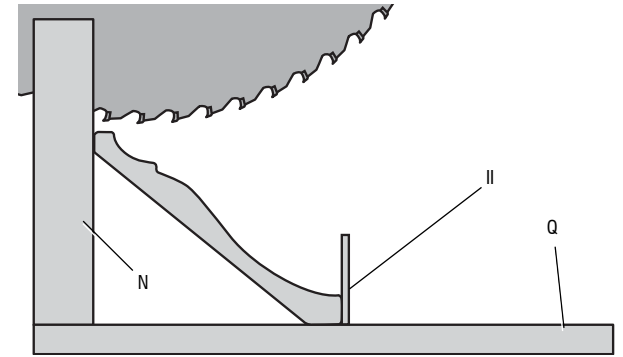
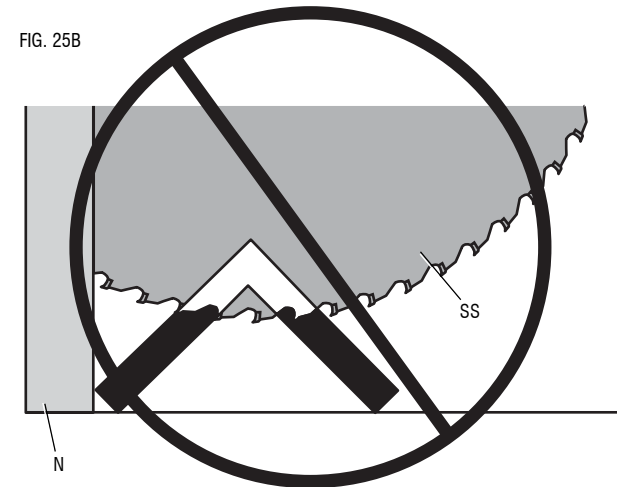

FIG. 25B



Cutting Crown Moulding (fig. 1, 24A, 24B)

Your mitre saw is well suited to the task of cutting crown moulding. In order to fit properly, crown moulding must be compound mitred with extreme accuracy.

Your mitre saw has special pre-set mitre latch points at 31.62° left and right for cutting crown moulding at the proper angle and bevel stop pawls at 33.86° left and right. There is also a mark on the bevel scale (K) at 33.9°. The chart below gives the proper settings for cutting crown moulding.

NOTE: Pretesting with scrap material is extremely important!

INSTRUCTIONS FOR CUTTING CROWN MOULDING LAYING FLAT AND USING THE COMPOUND FEATURES (FIG. 24A)

1. Moulding should lay flat with the broad back surface down on the saw table.
2. Place the top of the moulding against the fence.
3. The settings below are for 45° sprung crown moulding.

	INSIDE CORNER	OUTSIDE CORNER
Left side	Bevel left 30° Mitre table set at right 35.26° Save left end of cut	Bevel right 30° Mitre table set at left 35.26° Save left end of cut
Right side	Bevel right 30° Mitre table set at left 35.26° Save right end of cut	Bevel left 30° Mitre table set at right 35.26° Save right end of cut

4. The settings below are for crown moulding with 52° angles at the top and 38° angles at the bottom.

	INSIDE CORNER	OUTSIDE CORNER
Left side	Bevel left 33.9° Mitre table set at right 31.62° Save left end of cut	Bevel right 33.9° Mitre table set at left 31.62° Save left end of cut
Right side	Bevel right 33.9° Mitre table set at left 31.62° Save right end of cut	Bevel left 33.9° Mitre table set at right 31.62° Save right end of cut

FIG. 26A

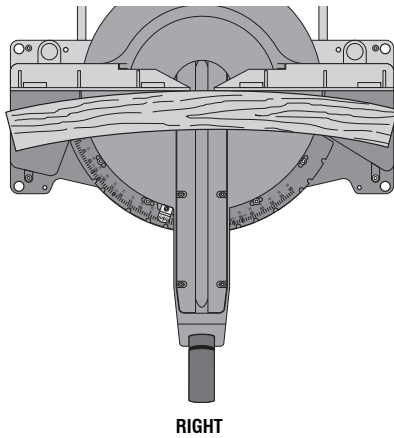

FIG. 26B

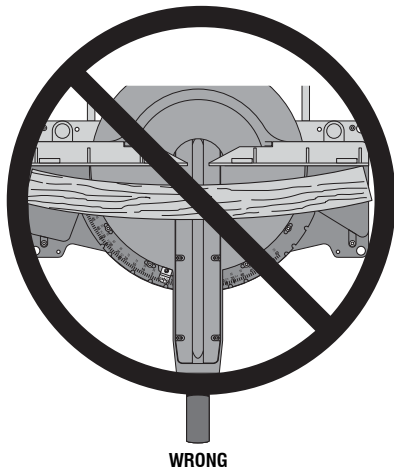
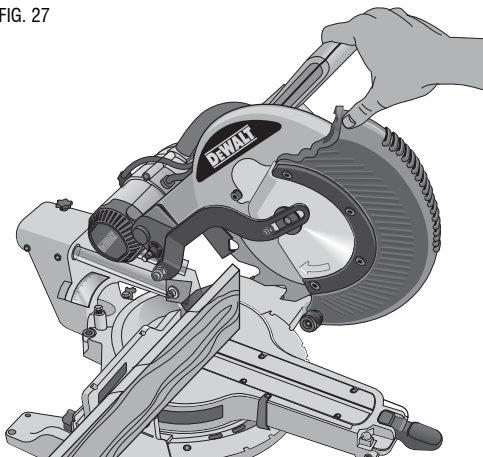

FIG. 27



Alternative Method for Cutting Crown Moulding

Cutting crown moulding using this method does not require a bevel cut. Minute changes in the mitre angle can be made without affecting the bevel angle. When corners other than 90° are encountered, the saw can be quickly and easily adjusted for them.

Use of the DW7084 crown moulding fence accessory (II) is highly recommended because of its degree of accuracy and convenience (fig. 5).

INSTRUCTIONS FOR CUTTING CROWN MOULDING ANGLED BETWEEN THE FENCE AND BASE OF THE SAW FOR ALL CUTS (FIG. 24B)

1. Angle the moulding so the bottom of the moulding (the part which goes against the wall when installed) is against the fence and the top of the moulding is resting on the saw table.
2. The angled "flats" on the back of the moulding must rest squarely on the fence and saw table.

	INSIDE CORNER	OUTSIDE CORNER
Left side	Mitre right at 45° Save right side of cut	Mitre left at 45° Save right side of cut
Right side	Mitre left at 45° Save left side of cut	Mitre right at 45° Save left side of cut

Special Cuts

⚠ WARNING: Never make any cut unless the material is secured on the table and against the fence.

ALUMINUM CUTTING (FIG. 25A, 25B)

ALWAYS USE THE APPROPRIATE SAW BLADE MADE ESPECIALLY FOR CUTTING ALUMINUM.

Certain workpieces may require the use of a clamp or fixture to prevent movement during the cut. Position the material so that you will be cutting the thinnest cross section, as shown in figure 25A. Figure 25B illustrates the wrong way to cut these extrusions.

Use a stick wax cutting lubricant when cutting aluminum. Apply the stick wax directly to the saw blade before cutting. Never apply stick wax to a moving blade. The wax provides proper lubrication and keeps chips from adhering to the blade.

BOWED MATERIAL (FIG. 26A, 26B)

When cutting bowed material always position it as shown in figure 26A and never like that shown in figure 26B. Positioning the material incorrectly will cause it to pinch the blade.

CUTTING PLASTIC PIPE OR OTHER ROUND MATERIAL

Plastic pipe can be easily cut with your saw. It should be cut just like wood and **clamped or held firmly to the fence to keep it from rolling.** This is extremely important when making angle cuts.

CUTTING LARGE MATERIAL (FIG. 1, 27)

Occasionally you will encounter a piece of wood a little too large to fit beneath the lower guard. If this occurs, place your right thumb on the upper side of the guard (A) and roll the guard up just enough to clear the workpiece, as shown in figure 27. Avoid doing this as much as possible, but if need be, the saw will operate properly and make the bigger cut. **NEVER TIE, TAPE, OR OTHERWISE HOLD THE GUARD OPEN WHEN OPERATING THIS SAW.**

SPECIAL SET-UP FOR WIDE CROSSCUTS (FIG. 28A, 28B)

Your saw can cut very wide (up to 409 mm [16.1"]) workpieces when a special set-up is used. To set the saw up for these workpieces, follow these steps:

FIG. 28A

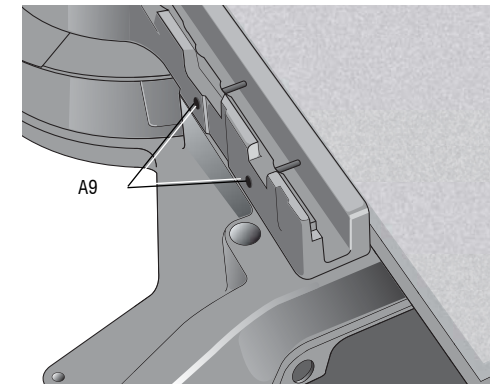
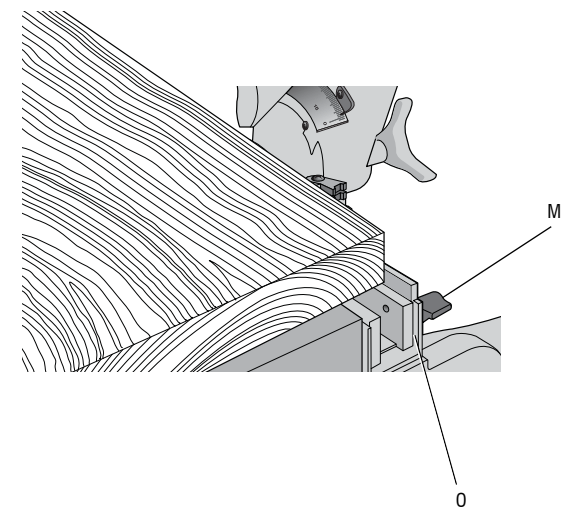

FIG. 28B



1. Remove both left and right sliding fences from the saw and set aside. To remove them, unscrew the fence adjustment knobs (M) several turns and slide each fence outward. Adjust and lock the mitre control so that it is at 0° mitre.
2. Make a platform using a piece of 38 mm (1.5") thick particleboard or similar flat strong 38 mm thick wood to the dimensions: 368 x 660 mm (14.5" x 26"). The platform must be flat, otherwise the material could move during cutting and cause injury.
3. Mount the 368 x 660 mm (14.5" x 26") platform to the saw using four 76.2 mm (3") long wood screws through the holes (A9) in the base fence (O) (fig. 28A). Four screws must be used to properly secure the material. When the special set-up is used, the platform will be cut into two pieces. Ensure the screws are tightened properly, otherwise material could loosen and cause injury. Ensure the platform is firmly flat on the table, against the fence, and centred evenly from left to right.

⚠WARNING: Ensure the saw is mounted firmly to a stable flat surface. Failure to do so could cause the saw to be unstable and fall causing personal injury.

- Place the workpiece to be cut on top of the platform mounted to the table. Ensure the workpiece is firmly against the back of the base fence (O) (fig. 28B).
- Secure the material before cutting. Cut slowly through the material using a out-down-and-back motion. Failure to clamp securely or cut slowly could result in the material coming loose and causing injury.

After several cuts are made at various mitre angles other than 0°, the platform may weaken and not properly support the work. Install a new, unused platform to the saw after presetting the desired mitre angle.

⚠CAUTION: Continued use of a platform with several kerfs may cause loss of material control and possible injury.

MAINTENANCE

DO NOT use lubricants or cleaners (particularly spray or aerosol) in the vicinity of the plastic guard. The polycarbonate material used in the guard is subject to attack by certain chemicals.

- All bearings are sealed. They are lubricated for life and need no further maintenance.
- Periodically clean all dust and wood chips from around AND UNDER the base and the rotary table. Even though slots are provided to allow debris to pass through, some dust will accumulate.
- The brushes are designed to give you several years of use. If they ever need replacement follow the **Brushes** instructions or return the tool to the nearest service center for repair. Service center locations are packed with your tool.

Brushes (fig. 1)

Inspect carbon brushes regularly. Keep brushes clean and sliding freely in their guides.

- Unplug tool, remove the motor end cap (F), lift the brush spring and withdraw the brush assembly.
- If the brushes are worn down to approximately 12.7 mm (1/2"), the springs will no longer exert pressure and they must be replaced.
- Use only identical DEWALT brushes. Use of the correct grade of brush is essential for proper operation of electric brake. New brush assemblies are available at DEWALT service centres.
- Always replace the brush inspection cap after inspection or servicing the brushes.
- The tool should be allowed to "run in" (run at no load) for 10 minutes before use to seat new brushes. The electric brake may be erratic in operation until the brushes are properly seated (worn in).
- While "running in" DO NOT TIE, TAPE, OR OTHERWISE LOCK THE TRIGGER SWITCH ON. HOLD BY HAND ONLY.

Cleaning

Before use, carefully check the upper guard, lower guard and dust duct to determine that they will operate properly. Ensure that chips, dust or workpiece particles do not block of one of the functions.

In case of workpiece fragments jammed between the saw blade and guards, disconnect the machine from the power supply and follow the instructions given in **Changing or Installing a New Saw Blade**. Remove the jammed parts and reassemble the saw blade.

Periodically clean all dust and wood chips from around AND UNDER the base and the rotary table.

⚠WARNING: Blow dirt and dust out of the main housing with dry air as often as dirt is seen collecting in and around the air vents. Wear approved eye protection and approved dust mask when performing this procedure.

⚠WARNING: Never use solvents or other harsh chemicals for cleaning the non-metallic parts of the tool. These chemicals may weaken the materials used in these parts. Use a cloth dampened only with water and mild soap. Never let any liquid get inside the tool; never immerse any part of the tool into a liquid.

WORKLIGHT CLEANING

- Carefully clean sawdust and debris from worklight lens with a cotton swab. Dust build-up can block the worklight and prevent it from accurately indicating the line of cut.
- DO NOT use solvents of any kind; they may damage the lens.
- With blade removed from saw, clean pitch and build-up from blade.

DUST DUCT CLEANING

With the saw unplugged and the saw head raised fully, low pressure air or a large diameter dowel rod can be used to clear the dust out of the dust duct.

Service Information

Please have the following information available for all service calls:

Model Number _____ Serial Number _____
Date and Place of Purchase _____

Repairs

To assure product SAFETY and RELIABILITY, repairs, maintenance and adjustment should be performed by a DEWALT factory service center, a DEWALT authorized service center or other qualified service personnel. Always use identical replacement parts.

Troubleshooting Guide

BE SURE TO FOLLOW SAFETY RULES AND INSTRUCTIONS

TROUBLE!	WHAT'S WRONG?	WHAT TO DO
Saw will not start	1. Saw not plugged in	1. Plug in saw.
	2. Fuse blown or circuit breaker tripped	2. Replace fuse or reset circuit breaker.
	3. Cord damaged	3. Have cord replaced by authorized service center.
	4. Brushes worn out	4. Have brushes replaced by authorized service center or replace them yourself. Refer to Brushes .
Saw makes unsatisfactory cuts	1. Dull blade	1. Replace blade. Refer to Changing or Installing a New Saw Blade .
	2. Blade mounted backwards	2. Turn blade around. Refer to Changing or Installing a New Saw Blade .
	3. Gum or pitch on blade	3. Remove blade and clean with coarse steel wool and turpentine or household oven cleaner.
	4. Incorrect blade for work being done	4. Change the blade type. Refer to Saw Blades under Optional Accessories .
Blade does not come up to speed	1. Extension cord too light or too long	1. Replace with adequate size cord. Refer to Use Proper Extension Cord under Important Safety Instructions .
	2. Low house current	2. Contact your electric company.
Machine vibrates excessively	1. Saw not mounted securely to stand or work bench	1. Tighten all mounting hardware. Refer to Bench Mounting .
	2. Stand or bench on uneven floor	2. Reposition on flat level surface. Refer to Familiarization .
	3. Damaged saw blade	3. Replace blade. Refer to Changing or Installing a New Saw Blade .
Does not make accurate miter cuts	1. Miter scale not adjusted correctly	1. Check and adjust. Refer to Miter Scale Adjustment under Adjustments .
	2. Blade is not square to fence	2. Check and adjust. Refer to Miter Scale Adjustment under Adjustments .
	3. Blade is not perpendicular to table	3. Check and adjust fence. Refer to Bevel Square to Table Adjustment under Adjustments .
	4. Workpiece moving	4. Clamp workpiece securely to fence or glue 120 grit sandpaper to fence with rubber cement.
Material pinches blade	1. Cutting bowed material	1. Refer to Bowed Material under Special Cuts .

TABLE 1: COMPOUND MITER CUT
 (POSITION WOOD WITH BROAD FLAT SIDE ON THE TABLE AND THE NARROW EDGE AGAINST THE FENCE)

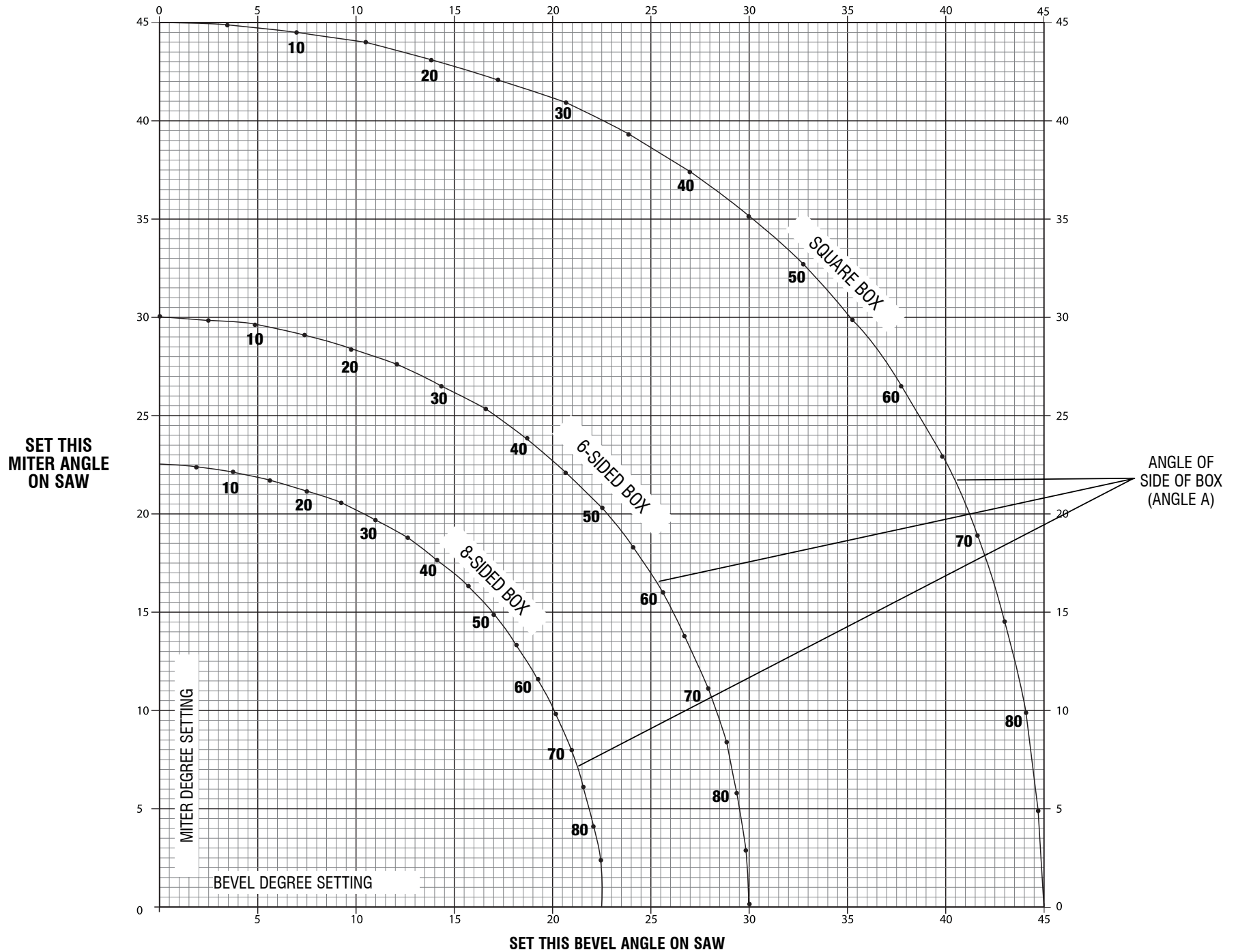

Stanley Black & Decker
701 East Joppa Road, Baltimore, MD 21286 • 82 Taryn Drive, Epping, VIC 3076 Australia
1800 444 224 (Aust) or 0800 339 258 (NZ)
www.dewalt.com.au • www.dewalt.com.nz.

(SEP11) Part No. N137372 DWS780-XE Copyright © 2011 DeWALT

The following are trademarks for one or more DeWALT power tools: the yellow and black color scheme; the "D" shaped air intake grill; the array of pyramids on the handgrip; the kit box configuration; and the array of lozenge-shaped humps on the surface of the tool.